



## Model DSN-20

### Nebula Swing Turnstile

DSN-20 is a swing turnstile product in the Daosafe Nebula series, with the following advantages:

- Passage width can reach to 600mm-1100mm, which is suitable for disabled person with wheelchair or pedestrians with luggage.
- Featuring a unique classic design, swing arm added dazzling LED strips, LED strips are seamlessly embedded in various parts of the case, making it modern and stylish.
- Constructed with a solid-body structure, the crate combines brushed stainless steel, high-end black powder coating, and side-mounted tempered glass, ensuring exceptional sturdiness.
- Ideal for installation in any high - end and elegant scenario, leaving a strong impression.

## Features

- Two way or one way working.
- 304/316 stainless steel material.
- 0.2s fast open speed, 40 person/min high throughput.
- Passage width can be extended to 650~1100mm.
- Lower power consumption.
- Low noise, system runs smoothly.
- Blue, green and red LED indicator display passing status.
- Indoor use.
- Support integrated with any type of access control systems.
- Fire safety requirements, arms open automatically.
- Easy to install and maintain.
- 3 years warranty support.

## Customized Service

- Appearance color can be customized based on installation environment.
- Dimensions can be customized to meet your request.
- Logo can be customized.
- Reader mount space can be customized.
- Arm glass width is optional.
- Infrared sensor number optional
- Waterproof outdoor can be customized.
- Picture: high resolution and 3D renderings pictures can be customized.

## Functions

- **Infrared sensor alarm function:**  
in case of illegal intrusion and reverse intrusion.
- **Anti-intrusion function:**  
the gate is locked automatically until valid opening signal input.
- **Anti-reverse function:**  
the turnstile alarms if someone wants to entry in the reverse direction.
- **Anti-trailing function:**  
the speed gate alarms if someone wants to burst in without permission.
- **Anti-collision and anti-kick function:**  
it designed with consolidated and more durable mechanism, will not break even someone collide it.
- **Mechanism self-protection:**  
the arm will reset automatically if off position. The movement will not be broken or damaged even hit.

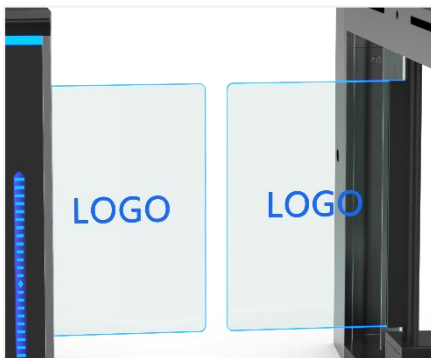

Logo Custom



LED Indicator



Wide Lane



Anti-reverse Function



Fire Safety Requirements,  
Arms Open Automatically



Anti-trailing Function

# Access Control System

Daosafe turnstile gates can be well integrated with any 3<sup>rd</sup> party access control systems



Card Solution



QR/Bar Code Solution



Biometric Solution



Remote Control



Touchless Button



Card



QR Code



Fingerprint



Face



Palm Vein

4 lanes DSN-20 with card solution installed at office

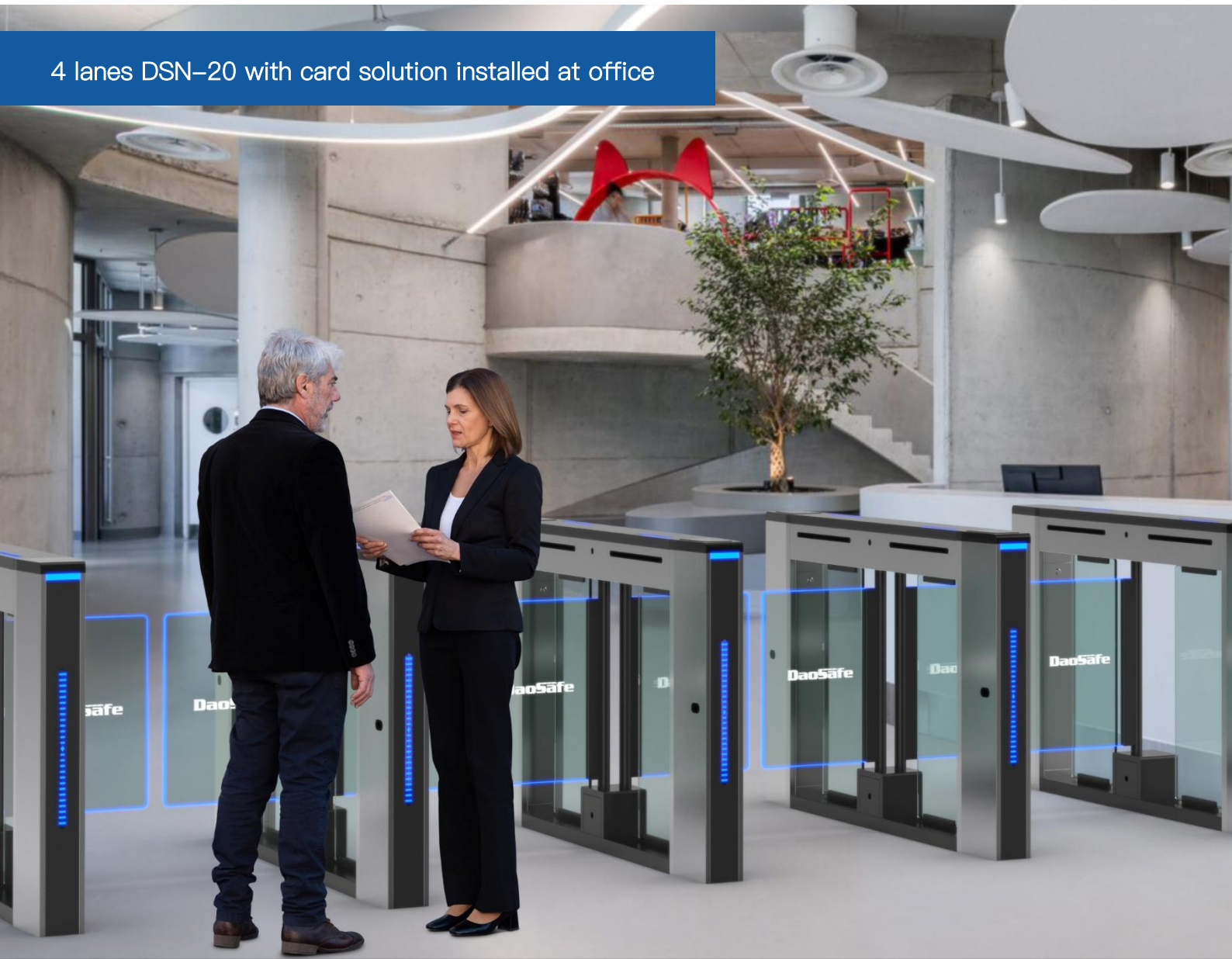

## Specifications

Model No.	DSN-20
Type	Nebula Swing Turnstile
Brand	Daosafe
Certifications	Compliance CE, ROHS, FCC
Framework Material	304 brushed stainless steel+ High end black powder coated
Arm Material	Plexiglass 10mm (standard) Tempered glass 8mm/10mm (optional)
Dimension	1600(L)*150(W)*980(H)mm
Net Weight	75kg/pcs (single core), 95kg/pcs (double core)
Passage Width	<ul style="list-style-type: none"> <li>• One unit: 650mm (standard)~1100mm (maximum)</li> <li>• 900mm (recommended disabled lane)</li> <li>• Wider width increases arm size and motor load.</li> </ul>
Arm Height	900mm
Passing Direction	Single directional/Bi-directional
MCBF	10 million
Power Supply	AC220V/110V, 50/60Hz
Operation Voltage	24V DC
Power Consumption	40W
Operation Temperature	-20 ~ 75°C (can be customized)
Operation Humidity	0 ~ 95% (No freeze)
IP Level	IP54 (standard)/IP65 (can be customized)
Working Environment	Indoor/Outdoor (can be customized)
Flow Rate	40 people per minute
LED Indicators (Strips)	Blue color: power on, green color: entry, red color: no entry
Infrared Sensor	6 pairs (standard)
Card Reader Mount	Under the top of the cabinet Max. dimensions: 130(L)*60(W)*25(T)mm (can be customized)
Communication	Dry contact, Relay signal, RS485
Emergency	Automatic arm open when power off
Flexibility	Integrate with any access control

# Dimensions

Parameter	Standard	Recommended (disabled)	Maximum	Note
Passage Width	600mm	900mm	1100mm	Wider width increases arm size and motor load
Arm Height	900mm	/	/	If need high arm, Nebula series DSN-70 speed gate is optional.

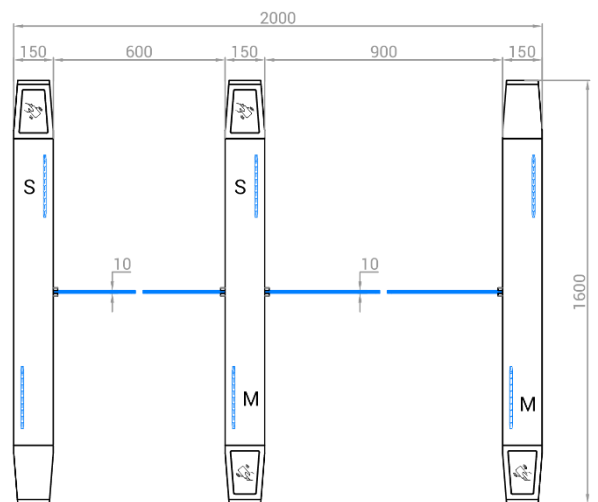
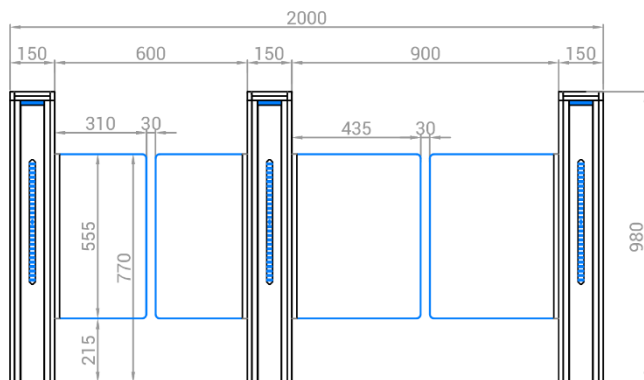
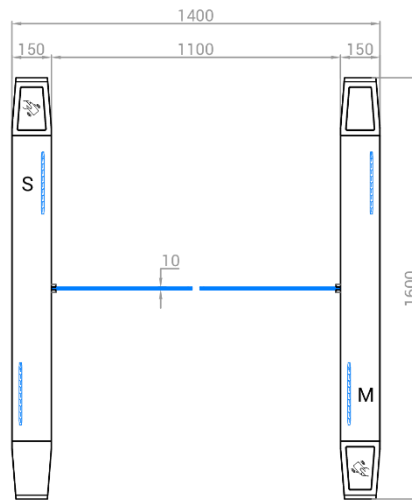
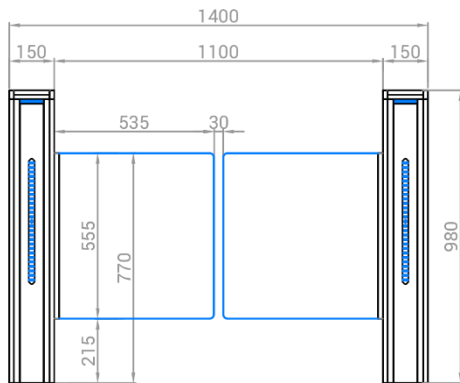
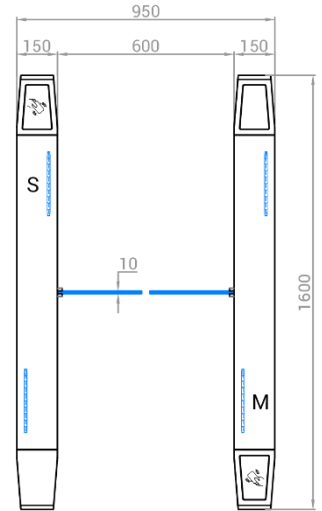
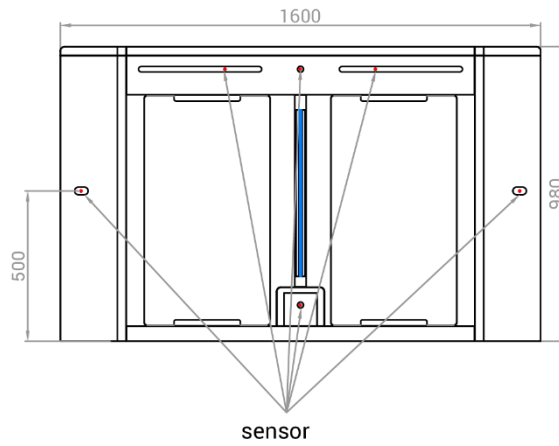
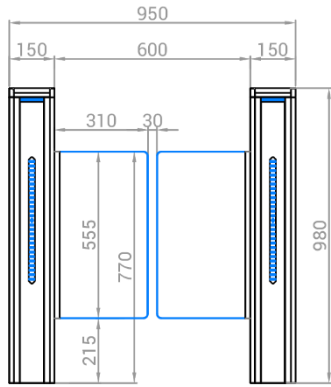

3 lanes DSN-20 with disabled lane installed at building



2 lanes DSN-30 with disabled lane DSN-20 installed at entrance

