



Model DS-Q50

Quantum Tripod Turnstile

DS-Q50 is most popular tripod turnstile. Its main advantages:

- Combines galvanized steel body with a sleek tempered glass top, offering a sophisticated and durable solution at an exceptional value.
- Top card reader uses green and red indicator lights to make passage smoother.
- With anti-trailing function, only one person to pass at one time, effectively preventing unauthorized trailing.
- Design with classic black, white color appearance, elegant and timeless pairing, perfect for using at high end applications.

Features

- Two way or one way working.
- Support integrated with any type of access control systems.
- Lower power consumption.
- Low noise, system runs smoothly.
- Green and red LED indicator display passing status.
- Fire safety requirements, arms drop down automatically.
- Easy to install and maintain.
- 3 years warranty support.

Customized Service

- Appearance color can be customized based on installation environment.
- Dimensions can be customized to meet your request.
- Logo can be customized.
- Reader mount space can be customized.
- Waterproof outdoor can be customized.
- Base optional: can add DSSP6005 base
- Picture: high resolution and 3D renderings pictures can be customized.
- The wireless remote control is available as a customized option, allowing front-desk staff to control the gate directly.



Logo Custom

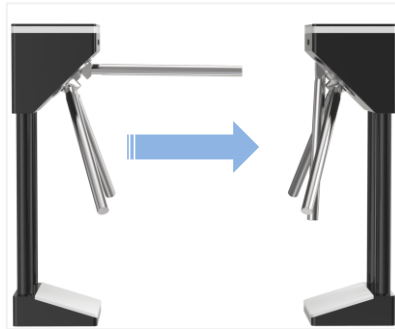

Arms Drop Down

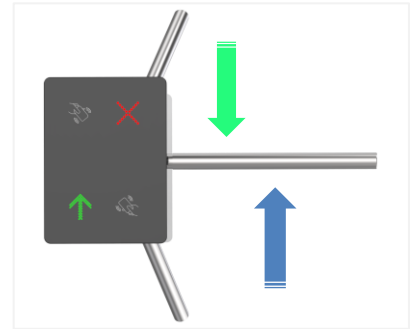

Single/Bi-directional



LED Indicator



Side Plexiglass

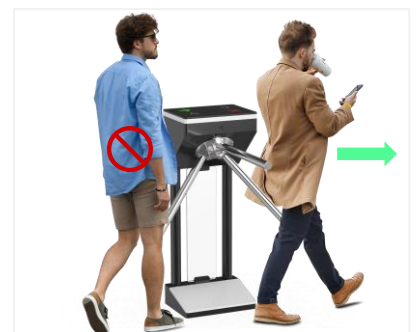

Anti-trailing Function

Access Control System

Daosafe turnstile gates can be well integrated with any 3rd party access control systems

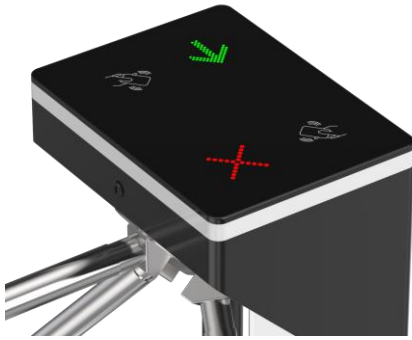

Card Solution

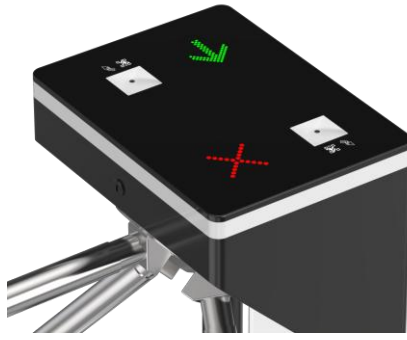

QR/Bar Code Solution



Biometric Solution



Remote Control



Touchless Button



Card



QR Code



Fingerprint



Face





Palm Vein

4 lanes for card solution installed at building



Specifications

Model No.	DS-Q50
Type	Quantum Tripod Turnstile
Brand	Daosafe
Certifications	Compliance CE, ROHS, FCC
Framework Material	Galvanized steel White and black powder coated Tempered glass
Arm material	304 Stainless Steel
Dimension	380(L)*280(W)*1000(H)mm
Net Weight	35kg/pcs
Passage Width	550mm (arm 500mm)
Passing Direction	Single directional/Bi-directional
MCBF	10 million
Power Supply	AC220V/110V, 50/60Hz
Operation Voltage	24V DC
Power Consumption	40W
Operation Temperature	-20 °C ~ 75 °C (can be customized)
Operation Humidity	0 ~ 95% (No freeze)
IP Level	IP54 (standard), IP65 (can be customized)
Working Environment	Indoor/Outdoor (can be customized)
Flow Rate	35 people per minute
LED Indicator	Authentication Status Light:  turns  (on valid scan)
Card Reader Mount	Under the top of the cabinet Max. dimensions: 100(L) * 80(W) * 25(T)mm (can be customized)
Emergency	Arm drop down automatic when power off
Communication	Dry contact, Relay signal, RS485
Flexibility	Integrate with any access control

Dimensions

Parameter	Standard	Recommended	Optional	Note
Passage Width	550mm	/	/	If need disabled lane, Quantum series DS-Q20 or DS-Q70 are optional
Arm Width	500mm	/	/	

Front View

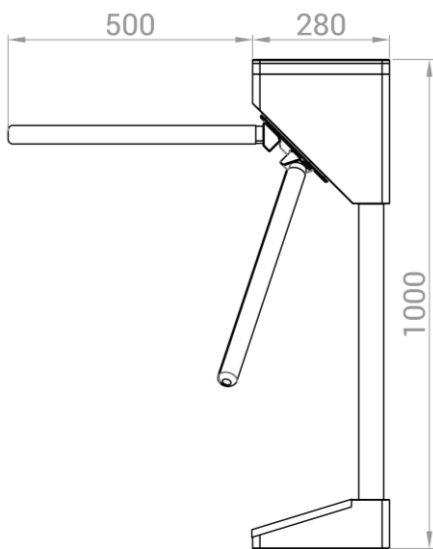

Side View

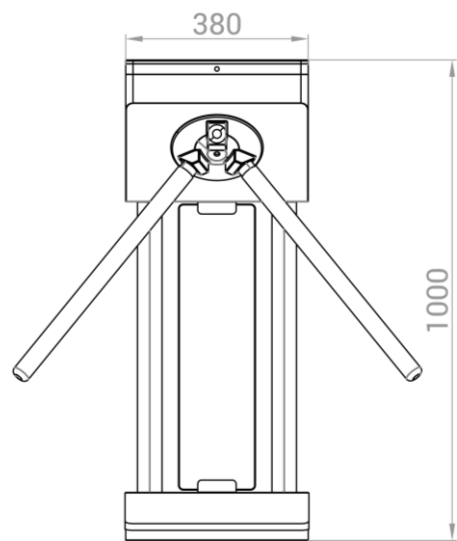

Top View

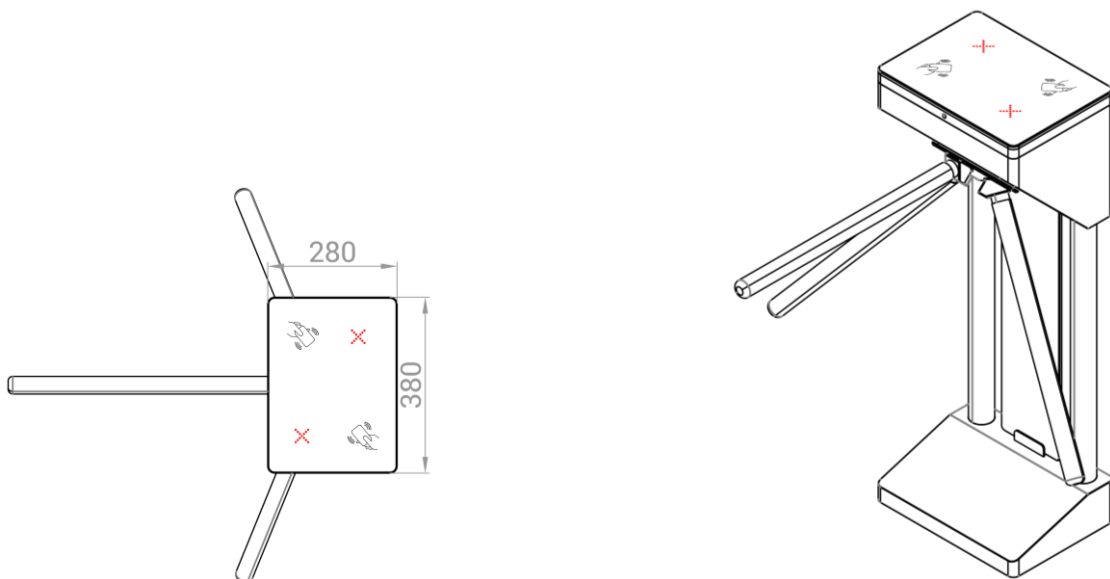

Lanes Solutions



One Lane

Two Lanes

Two Lanes with Disabled Access

Color Customization



Standard Color



Black Powder Coated



White Powder Coated

2 lanes DS-Q50 and DS-Q20 disabled lane installed at office



4 lanes DS-Q50 customized color installed at entrance

