



## Model DS112

### Tripod Turnstile

DS112 Tripod Turnstile with four major advantages:

- Clear Indication: Equipped with body light strips and top arrow lights, clearly indicating passage status and direction.
- Elegant Design: Featuring a brushed stainless steel body and curved styling, it combines durability with a modern look.
- High Security: Only one person can pass at a time, ensuring safety and preventing tailgating.
- Reliable Emergency: Compliant with fire safety requirements. The arm lowers automatically during a power failure for clear emergency passage.

## Features

- Two way or one way working.
- 304/316 stainless steel material.
- Support integrated with any type of access control systems.
- Lower power consumption.
- Low noise, system runs smoothly.
- Green and red LED indicator display passing status.
- Anti-tailing function: only one person passes at a time.
- Fire safety requirements, arms drop down automatically.
- Easy to install and maintain.
- 3 years warranty support.

## Customized Service

- Appearance color can be customized based on installation environment.
- Dimensions can be customized to meet your request.
- Logo can be customized.
- Reader mount space can be customized.
- Waterproof outdoor can be customized.
- Picture: high resolution and 3D renderings pictures can be customized.
- The wireless remote control is available as a customized option, allowing front-desk staff to control the gate directly.
- Base optional: can add DSSP6005 base



Logo Customization

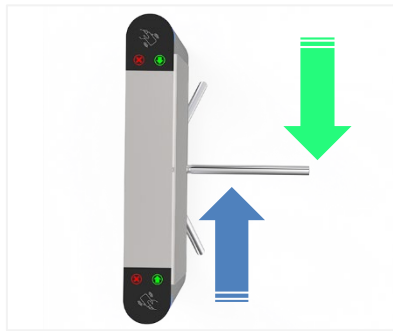

Single/Bi-directional Selectable



Tempered Glass Card Swiping



LED Indicator

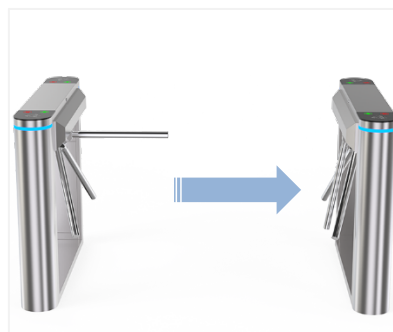

Arms Drop Down



Anti-tailing Function: one person can pass at a time

## Access Control System

Daosafe turnstile gates can be well integrated with any 3<sup>rd</sup> party access control systems



Card Solution



QR/Bar Code Solution



Biometric Solution



Remote Control



Touchless Button



Card



QR Code



Fingerprint



Face





Palm Vein

## Six lanes for card solution installed at building

Working with DSSP6003C Half Height Pedestrian Security Gate.



## Specifications

Model No.	DS112
Type	Tripod Turnstile
Brand	Daosafe
Certifications	Compliance CE, ROHS, FCC
Framework Material	304 brushed stainless steel
Arm material	304 Stainless Steel
Dimension	1200 * 185 * 980mm
Net Weight	50kg/pcs
Passage Width	550mm (arm 500mm)
Passing Direction	Single directional/Bi-directional
MCBF	10 million
Power Supply	AC220V/110V, 50/60Hz
Operation Voltage	24V DC
Power Consumption	40W
Operation Temperature	-20 °C ~ 75 °C (can be customized)
Operation Humidity	0 ~ 95% (No freeze)
IP Level	IP54 (standard), IP65 (can be customized)
Working Environment	Indoor/Outdoor (can be customized)
Flow Rate	35 people per minute
LED Indicators (Strips)	Blue color: power on, green color: entry, red color: no entry
LED Indicator (Top)	Constant Indicator Light:  Access Granted: 
Card Reader Mount	Under the top of the cabinet Max. dimensions: 90(L) * 80(W) * 25(T)mm (can be customized)
Emergency	Arm drop down automatic when power off
Communication	Dry contact, Relay signal, RS485
Flexibility	Integrate with any access control

## Dimensions

Parameter	Standard	Recommended	Optional	Note
Passage Width	550mm	/	600mm (can be customized)	If need disabled lane, DSSP6003ABC or DS8000 are optional
Arm Width	500mm	/	/	

Front View

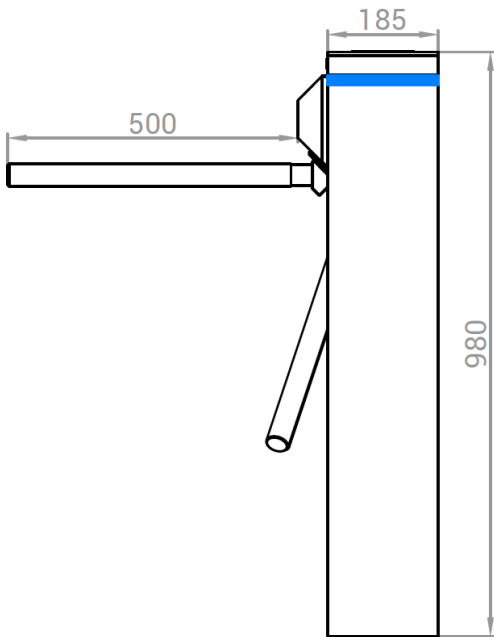

Side View

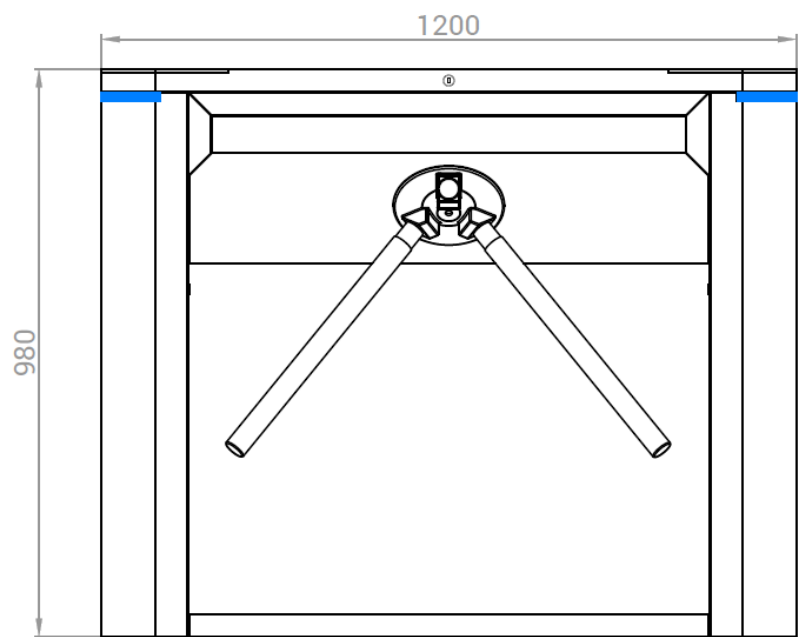

Top View

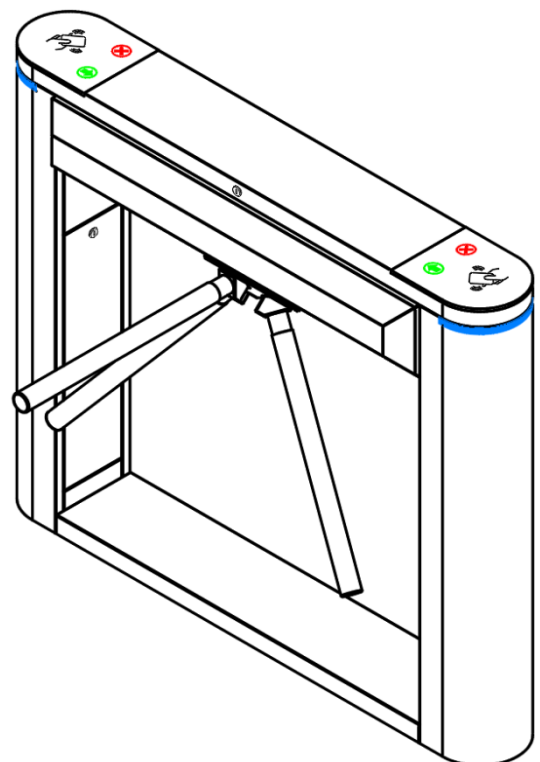
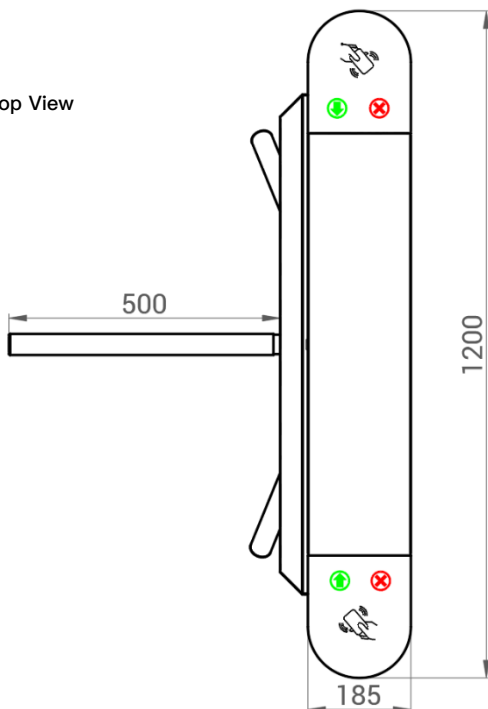

## Lanes Solutions



One Lane



Two Lanes



Two Lanes with Disabled Access

## Color Customization



Black Powder Coated



White Powder Coated



Standard Color

Five lanes for card solution installed at library



Working with DS8000  
Cylinder Speed Gate.

Four lanes for card processing have been installed in the office premises.

